

Powder Coated Metal Lockers

Periodic Maintenance

Hovik Lockers, featuring durable, double-pan, expanded honeycomb filled doors with continuous piano hinges and powder coated finishes are of the highest quality available. To ensure optimum performance, durability and longevity, the following periodic maintenance is recommended on a regular annual basis.

1. Tighten any screws and replace any popped rivets that have become loose due to vibrational forces or attempted vandalism.
2. Clean surfaces showing soil, grease, marks, etc. with warm water and a mild detergent (i.e.: Ivory Soap, Windex, Fantastic, etc.) followed by rinsing. Removing the excess moisture will renew the clean, even surface providing a pleasant sanitary appearance. Use of cleaners containing abrasives such as household cleaning powder, steel wool and harsh detergents, solvents or acids are not recommended.
3. Check surfaces for scratches and nicks. If these abrasions are deep and base metal is exposed, sand the area smooth. Paint the prepared area with air dry, touch-up enamel.
4. Lubricate the hinge (and positive single-point latch if applicable) periodically with a light grade (#10) machine oil. Operate door several times and wipe away excess oil.
5. Wax finished surfaces for added gloss and protection. Apply a coat of liquid or paste wax and rub to a glossy finish.

Manufacturers of Quality Metal Compartments and Lockers



STANDARD CONFIGURATION
TWO TIER LOCKER SHOWN

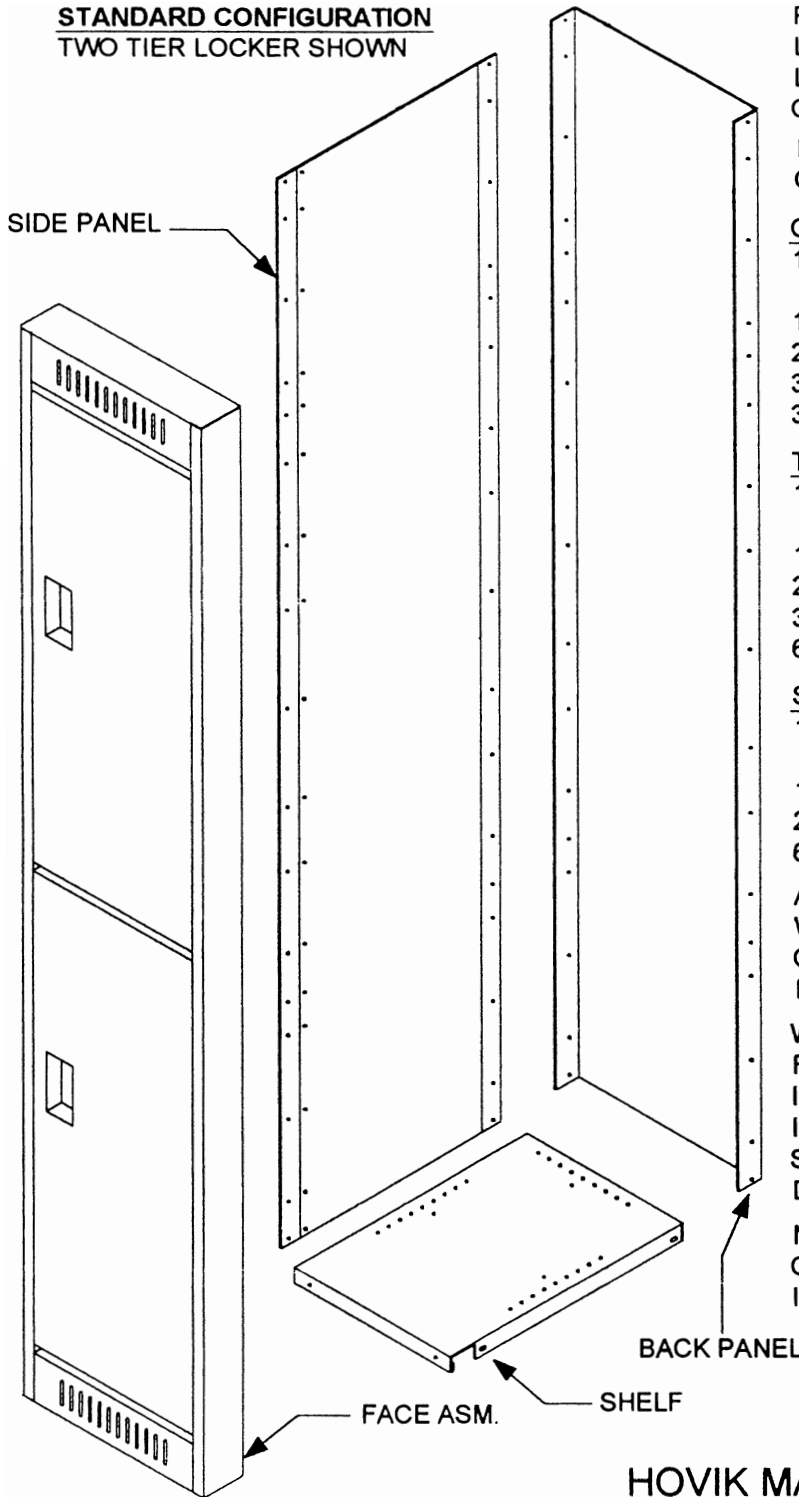

RIGHT HAND HINGE
LEFT TO RIGHT DOOR OPENING
LOCK RECESS ON LEFT SIDE
OF DOOR

EACH LOCKER ASSEMBLY
CONSISTS OF -

ONE TIER LOCKER

- 1 FRONT FACE ASSEMBLY
COMPLETE WITH DOORS
- 1 BACK PANEL
- 2 SIDE PANELS
- 3 SHELVES
- 3 COAT HOOKS

TWO TIER LOCKER

- 1 FRONT FACE ASSEMBLY
COMPLETE WITH DOORS
- 1 BACK PANEL
- 2 SIDE PANELS
- 3 SHELVES
- 6 COAT HOOKS

SIX TIER LOCKER

- 1 FRONT FACE ASSEMBLY
COMPLETE WITH DOORS
- 1 BACK PANEL
- 2 SIDE PANELS
- 6 SHELVES

ALL LOCKERS ARE SUPPLIED
WITH THE REQUIRED NUMBER
OF "SPUD" NUT AND BOLT
FASTENERS.

WHEN LOCKERS ARE SUPPLIED
FOR A MULTIPLE LOCKER
INSTALLATION WITH A COMMON
INSIDE SIDE PANEL, SURPLUS
SIDE PANELS WILL BE
DEDUCTED FROM ORDER.

NON STANDARD
CONFIGURATIONS AND
INSTALLATIONS CAN BE QUOTED.

HOVIK MANUFACTURING INC.

ASSEMBLY INSTRUCTIONS PAGE 1

STEP ONE LAY BACK PANEL ON A FLAT CLEAN SURFACE WITH FLANGE FACING UP

STEP TWO POSITION SIDE PANEL ON THE OUTSIDE OF BACK PANEL FLANGE, NOTE DOUBLE ROW OF HOLES MUST BE AT THE TOP.

STEP THREE FASTEN SIDE PANEL TO BACK PANEL, USE SECOND HOLE FROM THE TOP AND FIRST HOLE FROM THE BOTTOM. THIS WILL ALLOW THE ASSEMBLY TO STAND ON ITS OWN TO FACILITATE SHELF ASSEMBLY.

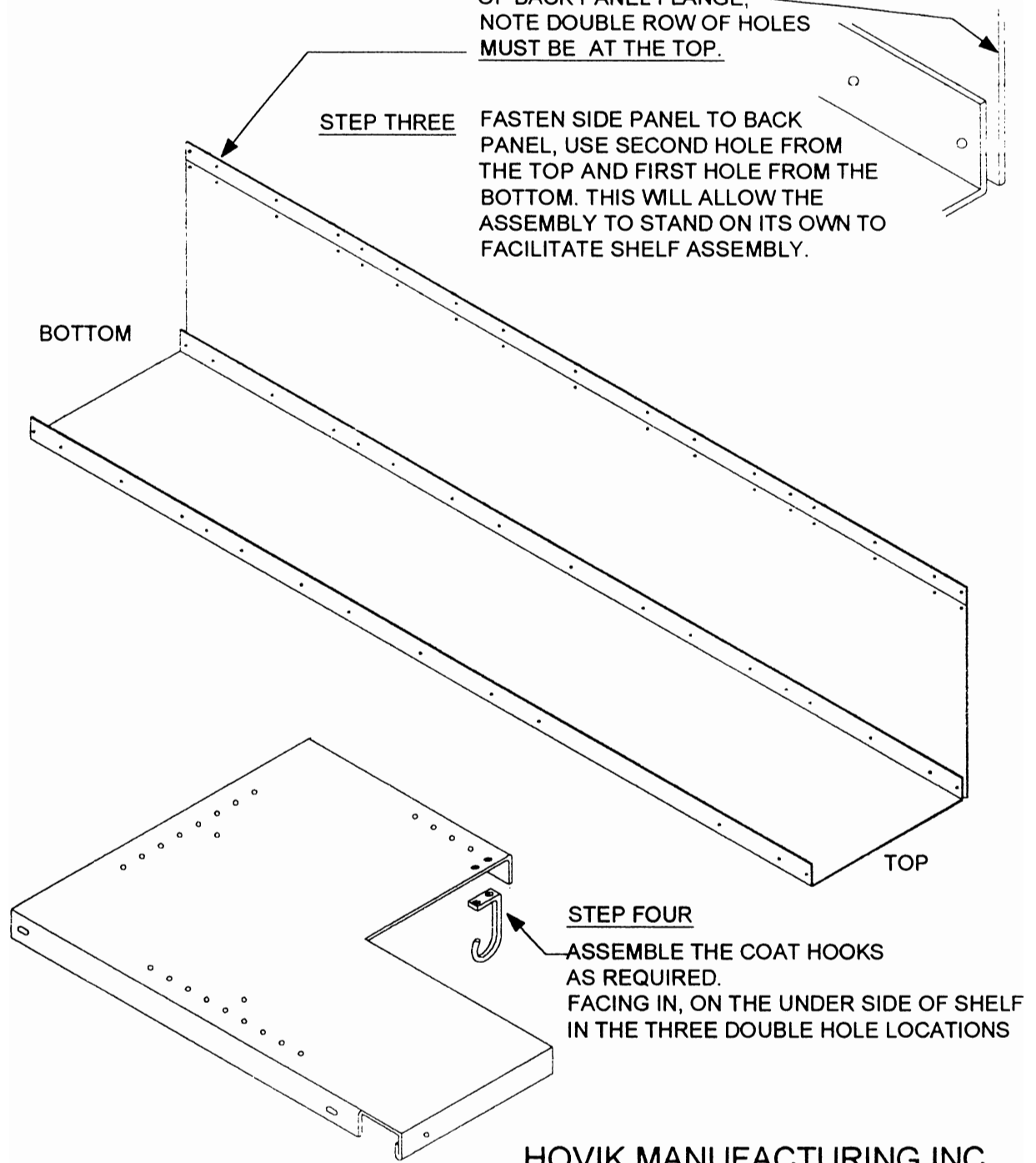

HOVIK MANUFACTURING INC.

ASSEMBLY INSTRUCTIONS PAGE 2

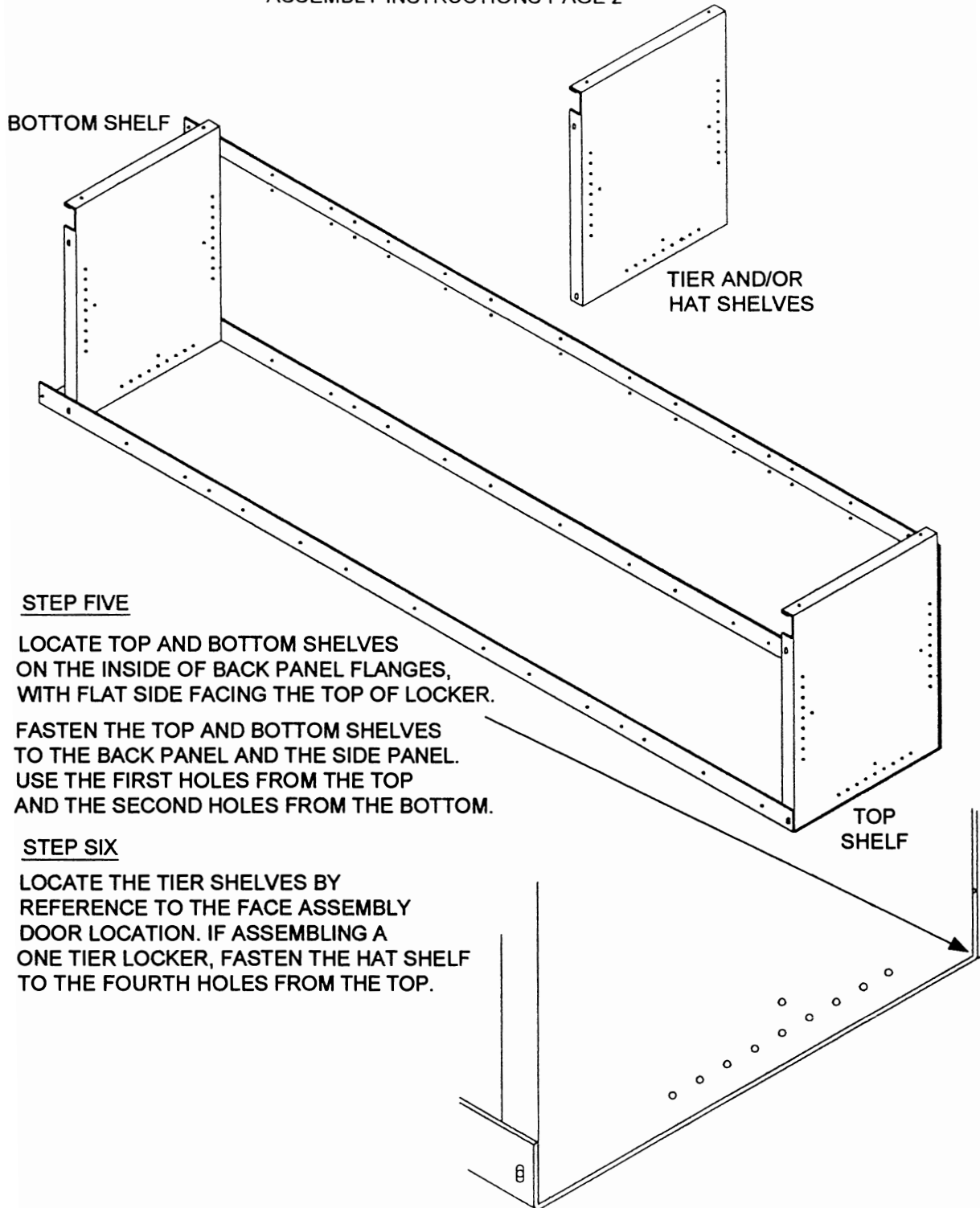

STEP FIVE

LOCATE TOP AND BOTTOM SHELVES ON THE INSIDE OF BACK PANEL FLANGES, WITH FLAT SIDE FACING THE TOP OF LOCKER.

FASTEN THE TOP AND BOTTOM SHELVES TO THE BACK PANEL AND THE SIDE PANEL. USE THE FIRST HOLES FROM THE TOP AND THE SECOND HOLES FROM THE BOTTOM.

STEP SIX

LOCATE THE TIER SHELVES BY REFERENCE TO THE FACE ASSEMBLY DOOR LOCATION. IF ASSEMBLING A ONE TIER LOCKER, FASTEN THE HAT SHELF TO THE FOURTH HOLES FROM THE TOP.

HOVIK MANUFACTURING INC.

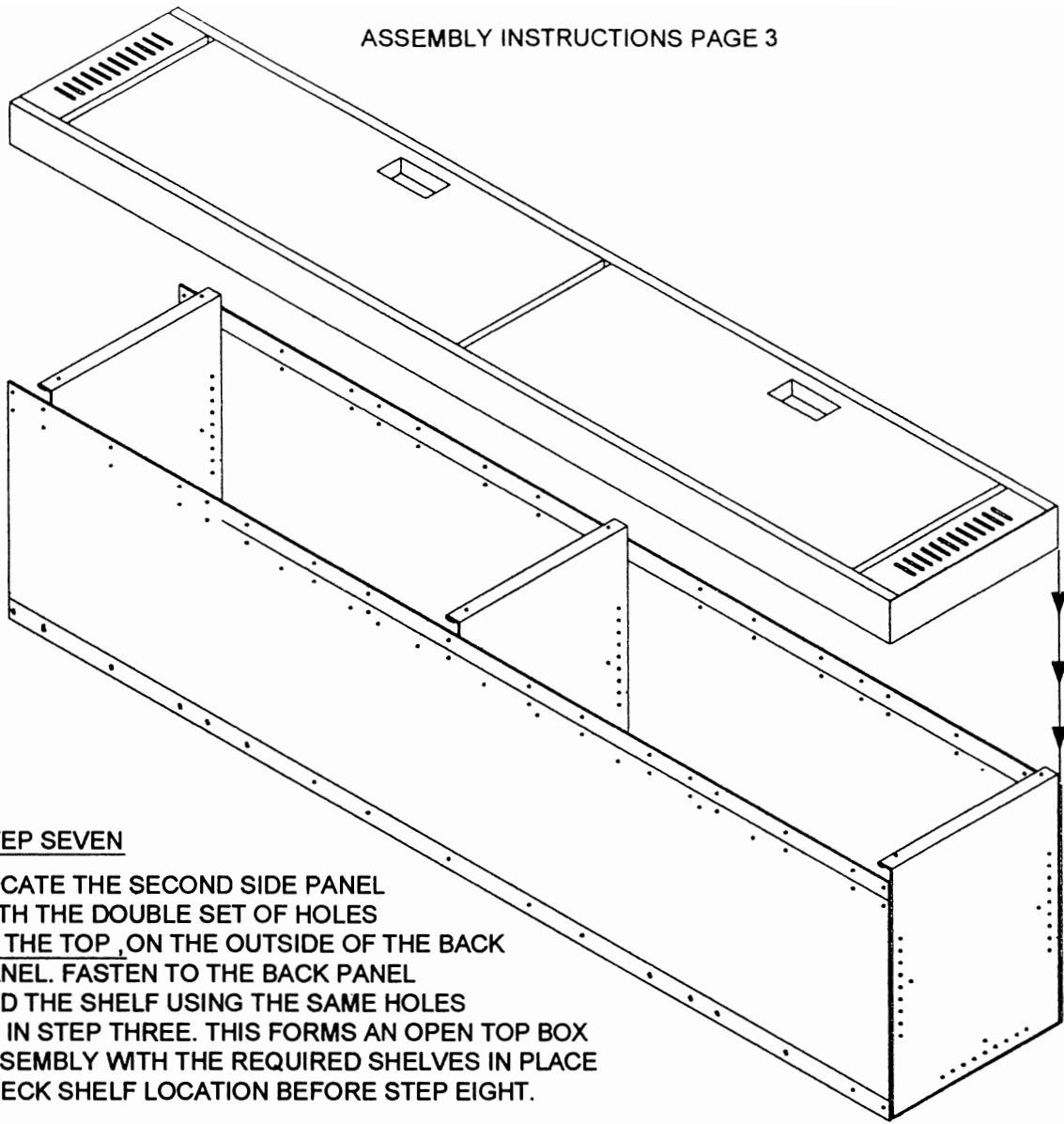

STEP SEVEN

LOCATE THE SECOND SIDE PANEL WITH THE DOUBLE SET OF HOLES AT THE TOP, ON THE OUTSIDE OF THE BACK PANEL. FASTEN TO THE BACK PANEL AND THE SHELF USING THE SAME HOLES AS IN STEP THREE. THIS FORMS AN OPEN TOP BOX ASSEMBLY WITH THE REQUIRED SHELVES IN PLACE CHECK SHELF LOCATION BEFORE STEP EIGHT.

NOTE - IF MULTIPLE LOCKERS ARE BEING ASSEMBLED THE NEXT LOCKER IS STARTED BY FASTENING THE BACK PANEL AND SHELVES TO THE COMMON SIDE PANEL IN STEP SEVEN.

STEP EIGHT

LOCATE THE FACE ASSEMBLY ONTO THE BOX ASSEMBLY IT FITS BETWEEN THE SIDE PANELS AND THE SHELVES AND LINES UP WITH THE TOP ROW OF HOLES ON THE SIDE PANEL FASTEN BOTH ASSEMBLIES TOGETHER ALONG THE SIDES. OPEN DOORS AND FASTEN THE FRONT EDGE OF SHELVES TO THE FRONT ASSEMBLY.

HOVIK MANUFACTURING INC.